





Task luminaires enable specific illumination of the workplace and individual operation by the user. They provide direct light for reading, writing, or operating the computer.

As an additional, individually adjustable lighting component, task luminaires today fulfill the recognized task of compensating for poor eyesight with higher brightness levels and an individually selectable light incidence direction. They are highly regarded among users.

For task luminaires in professional applications

## **DIN 5035-8 “Artificial lighting of interiors, Part 8: Task luminaires – Requirements, recommendations and testing“**

has outlined all relevant product properties since 2007. The standard focuses on performance capability characteristics. These include:

- Lighting technology characteristics, such as the brightness levels produced on reference surfaces in reference positions and their uniformity
- Product-specific measures for limiting glare
- Mechanical and electrical adjustment options
- The design of operating elements and displays
- Optical properties, such as gloss level and reflection level
- Thermal characteristics, such as the surface temperature on defined areas and heat emission

The conformity of the MAIA task luminaire with the requirements of the standard DIN 5035-8 is documented as follows on the next few pages:

1. Product data
2. Lighting technology data
3. Adjustment options
4. Displays and operating elements
5. Additional performance capability characteristics
6. Maintenance, repair, care, disposal
7. Contact



## 1. Product data

Luminaire name:	MAIA
Type / model:	DTE 111 F
Item number	112293000
Connected loads:	230-240 V, 50/60 Hz
Equipped with:	1x compact fluorescent lamp 11W/840 (lamp base 2G7)
Operating device:	1x electronic ballast OSRAM DT-S/E 5-11/230-240 S
System output:	approx. 12 W
Standby power:	0 W
Connecting line:	approx. 11 ft, Euro plug
Operation:	Switchable
Weight:	approx. 1.3 kg
Diffusion:	AMBIO microprism disk
Protection class:	II
Housing:	Plastic, stamped aluminum
Rods:	Aluminum profile, anodized
Arm balance	Gas pressure spring
Safety signs:	CE, ENEC

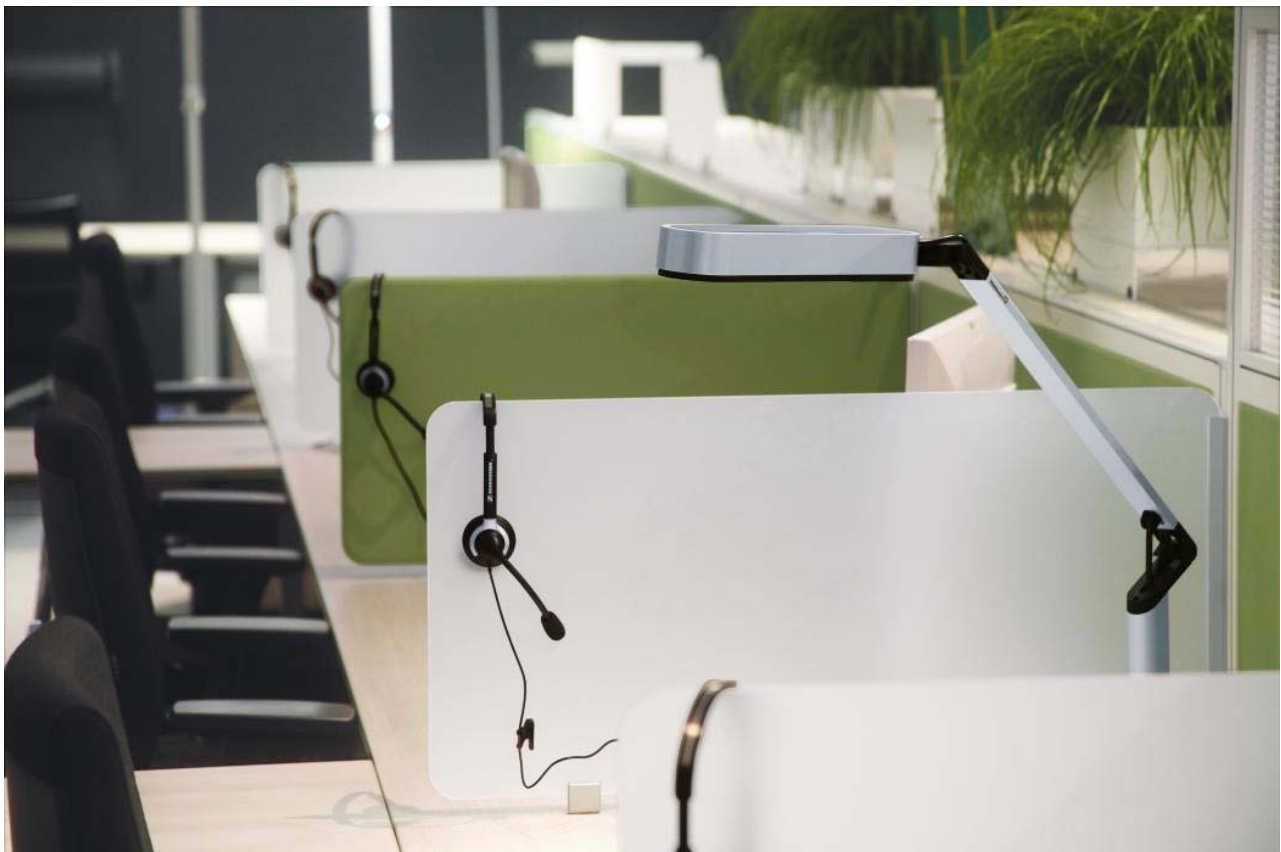

## 2. Lighting technology data

### Reference surface (RF) and reference position

RF3 (L x B) = 600 mm x 600 mm, number of measurement points at least 10 x 10

Luminaire centered over RF, horizontally at a distance of 500 mm over RF (see sketch)

Reference lamp luminous flux according to ballast-lamp combination: 900 lm

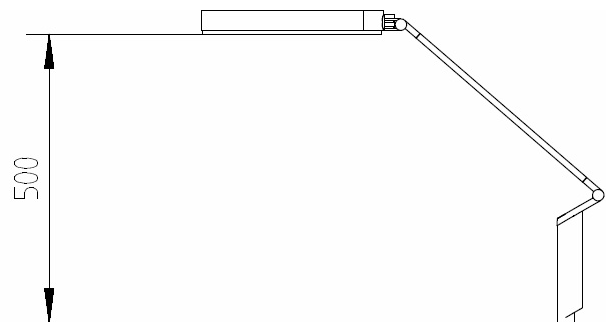
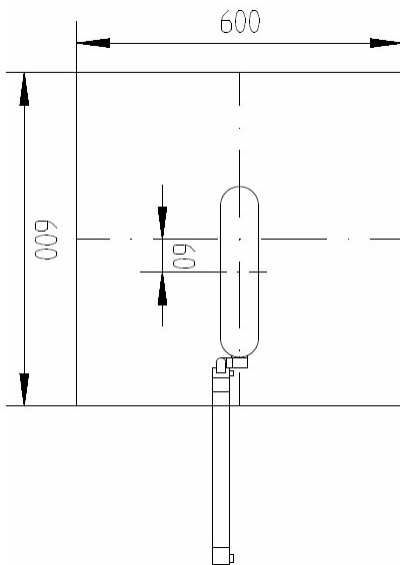

### 2.1 Brightness levels

The brightness level greatly influences how quickly, how safely, and how easily the eyes can handle a visual task – for example when reading or working on the computer.

The brightness level (abbreviated: E) indicates, in the unit of measure lux (lx), the luminous flux (measured in lumen: lm) that a light source emits onto a defined surface. It is one lux if the luminous flux of one lumen illuminates an area of one square meter.

The brightness level is measured on horizontal and vertical surfaces using a lux meter. For office tasks, for example the standard DIN EN 12464-1 (Lighting of workplaces – Indoor workplaces) specifies an average brightness level of greater than 500 lux in the area of a visual task. If necessary, task luminaires assume the function of supplementing the existing basic illumination (artificial and/or daylight) in order to meet the requirement.

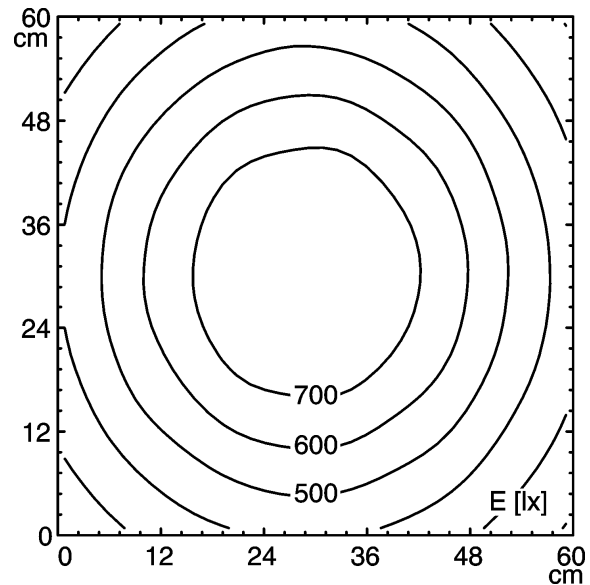
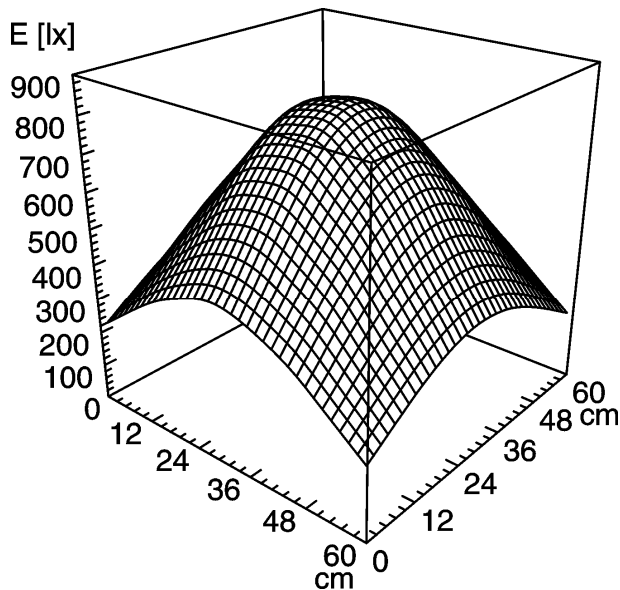

Measurement results for brightness level of MAIA in lux:

Minimum brightness level	Maximum brightness level	Average brightness level
$E_{\min} = 239 \text{ lx}$	$E_{\max} = 810 \text{ lx}$	$E_{\text{mean}} = 529 \text{ lx}$

## 2.2 Uniformity

The uniform distribution of the brightness facilitates the visual task and/or prevents the creation of unpleasant brightness differences and therefore the distraction from the visual task. Uniform means the distribution of the brightness level, i.e. it is e.g. the ratio of the minimum to the maximum brightness level ( $g_2$ ), or the standard deviation from the average brightness level ( $g_3$ ).

Uniformity levels for measurement result from MAIA:

Uniformity $g_2$	Uniformity $g_3$
0.30 (the higher the better, at least 0.20)	$g_3 = 0.28$ (the smaller the better, maximum 1.0)

## 2.3 Limitation of glare

Luminance (abbreviated: L) corresponds to the luminous intensity (I) relative to a square measure and thus constitutes the impression of brightness that the viewer perceives from a light source. Glare is caused by areas with excessive luminance. For task luminaires, according to DIN 5035-8, product-specific measures are required for limiting glare.

For luminaires operated above eye level (MAIA), the cut-off angles according to DIN EN 12464-1 must be adhered to. If luminaires such as the task luminaire MAIA are operated below eye level, a cut-off angle of at least  $0^\circ$  must be adhered to. The direct view of the lamp is prevented on the MAIA luminaire by the AMBIO microprism disk.



Average luminance (relative to nominal luminous flux):

	C0	C15	C30	C45	C60	C75	C90	C105	C120	C135	C150	C165
65°	2890	2613	2499	3018	3296	3112	2842	3122	3312	2706	2462	2621
70°	2642	2397	2402	2649	3091	2909	2819	2918	3156	2556	2306	2502
75°	2392	2327	2332	2723	2918	2997	2810	3137	2932	2599	2334	2334
80°	2023	2120	2317	2513	2803	3011	3117	3020	2719	2518	2223	2029
85°	1344	1536	1924	2311	2696	3096	3299	3105	2709	2315	1925	1733
	C180	C195	C210	C225	C240	C255	C270	C285	C300	C315	C330	C345
65°	2862	2464	2539	3131	3461	2996	3048	3362	[3508]	2814	2534	2611
70°	2603	2407	2451	2889	3245	3011	3023	3115	3251	2693	2348	2444
75°	2401	2466	2461	2847	3054	3196	3143	3137	2929	2718	2392	2390
80°	2031	2128	2317	2508	2808	3111	3123	2922	2717	2411	2216	2118
85°	1542	1542	1731	1922	2315	2712	2722	2523	1933	1729	1536	1343

Luminance (cd/m<sup>2</sup>)

The brightness sensation is furthermore limited by use of the glare-free technology AMBIO. The core of AMBIO is a prism disk, whose surface consists of numerous microprisms. As a result, the MAIA task luminaire achieves optimized and uniform all-round diffusion.

## 2.4 Light distribution

The spatial distribution of the brightness level is illustrated by way of the luminous intensity-distribution curve (LVK). The light distribution of the MAIA task luminaire is direct 100%, and the luminaire efficiency is 37%.

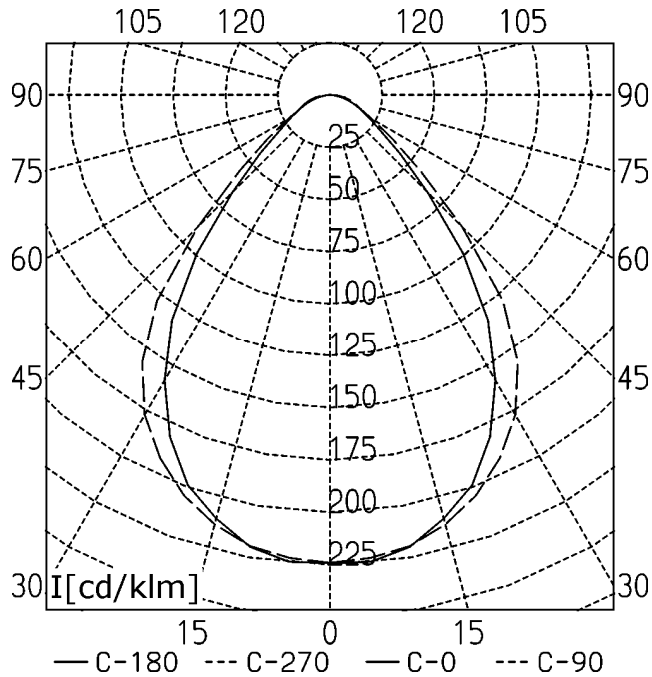

### 3. Adjustment options

The MAIA luminaire is designed for typical office and desk activities in addition to daylight or room lighting. The luminaire is typically operated at head level or below and adjusted in accordance with the individual vision requirements (distance and inclination of the luminaire head). The adjustments can be easily and, with frequent use, quickly performed by the user. A high-quality joint design ensures that adjustments selected by the user are not accidentally changed, even over extended periods.

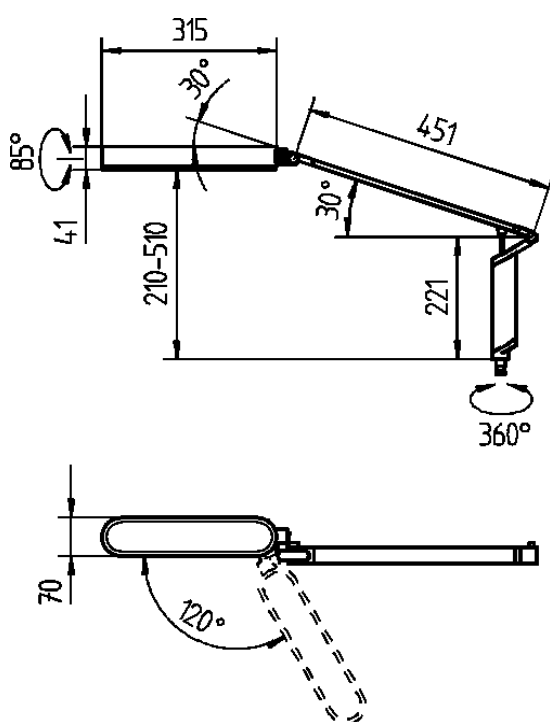

## **4. Displays and operating elements**

The operating element of the MAIA task luminaire is installed in the luminaire head and therefore always within reach. The shape is ergonomical and has a clear design with respect to the function of the switch.



The function of the switch is limited to switching the switch on and off. These steps are performed intuitively and easily using the rocking feature.

## **5. Additional performance capability characteristics**

### **5.1 Noise emission**

The MAIA luminaire only produces minimal noise during mechanical adjustment. No noise emission is created by the electrical components.

### **5.2 Optical surface properties**

Anodized aluminum and black, matte plastic form the key surfaces of the MAIA task luminaire. The gloss and reflection levels of these surfaces are minimal and do not produce any unpleasant reflections during use.



### 5.3 Mechanical features

When adjusting the luminaire to the individual vision requirements, mechanical components are moved. The minimum distance between the moving parts has been increased so that no risk of pinching or shear for fingers exists.



All edges and material transitions are deburred. There is no risk of cuts during the intended operation.

Different fastening options (table clamp, table base) ensure standard-compliant structural stability (DIN EN 60598-2-4) of the variable MAIA luminaire. The luminaire is normally shipped with the table clamp and can alternatively be operated with a table base.



Due to the desired mobility of the luminaire, it must be protected from tilting or falling of the desk when in use:

- Mount luminaire with the listed accessory (table clamp, table base) on the desk
- Route cable so it cannot be damaged
- Any fastening options different from those proposed by Waldmann must be inspected for effectiveness

## 5.4 Thermal features

The components used in the MAIA task luminaire, the electronic ballast, and the compact fluorescent lamp hardly emit heat during operation. An impairment of the user, especially in the head region, is excluded.

For components with which the user may have specific or accidental contact during intended use, limit values for the surface temperatures must be adhered to. These depend on the materials of the luminaire parts and the duration of contact of the user with the parts. The values listed below refer to the use in the professional field, i.e. by employees with common reaction times and durations of operation.

Relevant standards: DIN EN ISO 13732-1:2004-04 and DIN EN 60598-1.

### **Maximum surface temperature on contact with the luminaire parts:**

At an ambient temperature of 25°C, a maximum surface temperature (metal parts) of 52.9°C is achieved (limit: 60°C).

## **6. Maintenance, repair, care, disposal**

The MAIA luminaire is maintenance-free with the exception of the lamp.

Before performing maintenance and repair work, the luminaire must be disconnected from the mains. The work must only be conducted by a trained electrical technician.

Only parts released by Waldmann as the manufacturer (e.g. approved type of lamp) may be used as spare parts. A damaged mains line may only be replaced by Waldmann.

A piece of cloth soaked with common household cleaner should be used to clean the luminaire parts.

At the end of the service life, the MAIA task luminaire must be taken to the existing return and collection systems.

All information relating to maintenance, repair, care, and disposal is part of the user instructions. They are enclosed for every new product that is shipped and, if necessary, can also be requested later from Waldmann.

## **7. Contact**

For additional information and to contact us, visit

**[www.waldmann.com](http://www.waldmann.com)**